

Name: _____

- 1) A glass sphere and a lead sphere have the same volume. Each sphere is dropped into a container of water. Which statement best explains why the lead sphere settles faster?
- A) The lead sphere has a higher density.
 - B) The lead sphere takes up less space.
 - C) The glass sphere has more surface area.
 - D) The glass sphere has a smoother surface.
- 2) Which graph shows the relationship between the density of particles and their settling time in still water? [Assume that the particles have the same size and shape.]

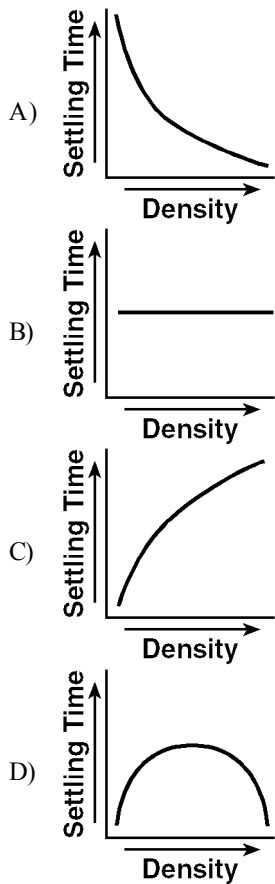

- 3) The map below represents a view of a flowing stream. The letters identify locations in the stream near the interface between land and water. At which two locations is erosion due to flowing water likely to be *greatest*?

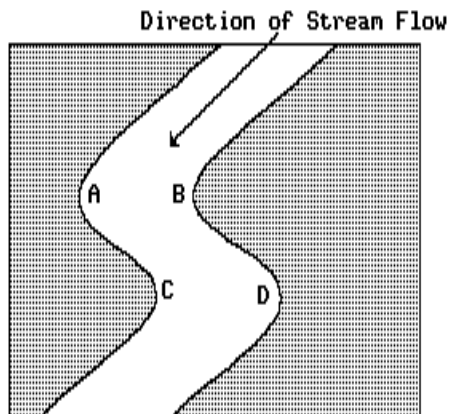

- A) A and D
 - B) A and B
 - C) B and D
 - D) B and C
- 4) If all the particles below have the same mass and density, which particle will settle fastest in quiet water? [Assume settling takes place as shown by arrows.]

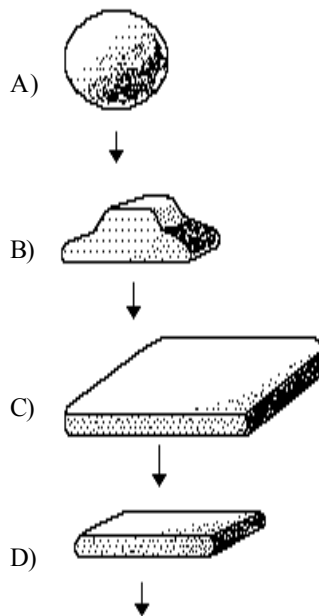

- 5) The particles in a sand dune deposit are small and very well-sorted and have surface pits that give them a frosted appearance. This deposit most likely was transported by
- A) gravity
 - B) wind
 - C) glacial ice
 - D) ocean currents

- 6) The diagram below represents two branches of a valley glacier. Points *A*, *B*, *G*, and *H* are located on the surface of the glacier. Point *X* is located at the interface between the ice and the bedrock. The arrows indicate the general direction of ice movement.

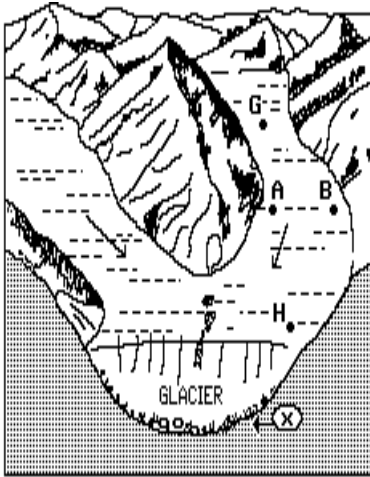

The sediment deposited by the valley glacier at position *X* is best described as

- A) sorted according to particle density
 B) sorted according to particle size
 C) sorted according to particle texture
 D) unsorted
- 7) A state of dynamic equilibrium exists in an erosional-depositional system when
- A) the rate of erosion is the same as the rate of deposition
 B) the rate of erosion exceeds the rate of deposition
 C) the amounts of kinetic energy and potential energy both equal zero
 D) all sediments are transported to the sea and erosion stops

- 8) The diagram below shows three beds of sediment deposited at different times in a quiet body of water.

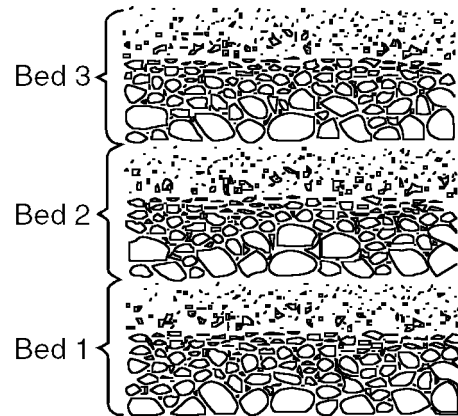

The sediment deposited in each bed is *best* described as

- A) sorted mainly according to particle shape
 B) a mixture of sorted and unsorted particles
 C) sorted mainly according to particle size
 D) showing no evidence of sorting
- 9) Which diagram *best* illustrates a cross section of sediments that were transported and deposited by a glacier?

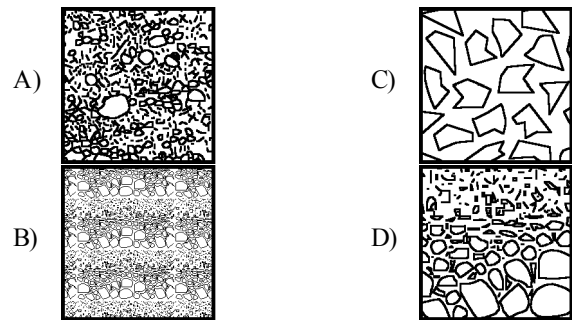

- 10) The chart below shows the results of an activity in which three samples of copper (*A*, *B*, and *C*) of equal mass were timed as they settled to the bottom of a column of water.

SAMPLE A	SAMPLE B	SAMPLE C
13.10 sec	13.75 sec	13.50 sec

The differences in the settling time of the three samples are probably due to difference in their

- A) color
 B) density
 C) shape
 D) composition
- 11) Which rock particles will remain suspended in water for the longest time?
- A) pebbles
 B) silt
 C) clay
 D) sand
- 12) Which erosional agent typically deposits hills of unsorted sediments?
- A) ocean waves
 B) glaciers
 C) winds
 D) streams

- 13) Four samples of aluminum, *A*, *B*, *C*, and *D*, have identical volumes and densities, but different shapes. Each piece is dropped into a long tube filled with water. The time each sample takes to settle to the bottom of the tube is shown in the table below.

Sample	Time to Settle (sec)
<i>A</i>	2.5
<i>B</i>	3.7
<i>C</i>	4.0
<i>D</i>	5.2

Which diagram most likely represents the shape of sample *A*?

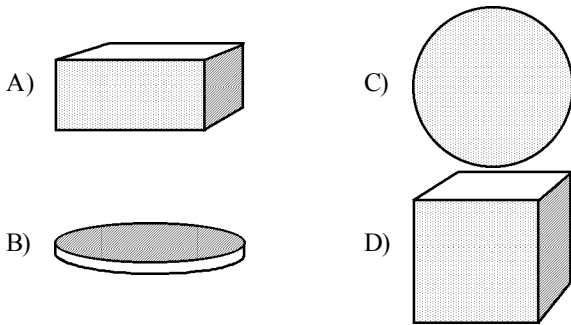

- 14) A large, scratched boulder is found in a mixture of unsorted, smaller sediments forming a hill in central New York State. Which agent of erosion most likely transported and then deposited this boulder?
- A) ocean waves C) a glacier
 B) running water D) wind
- 15) The diagram below represents a river flowing into a large lake on a hot, sunny afternoon in July in New York State. The river is carrying particles ranging in size from cobbles to clay.

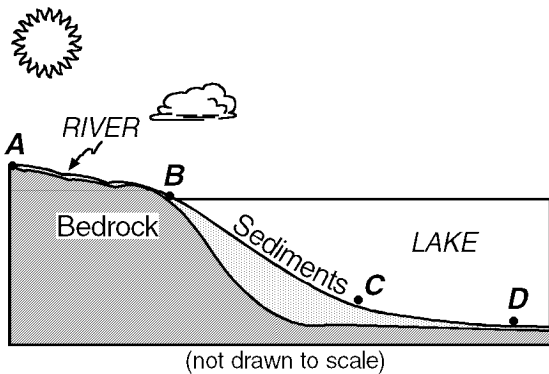

When water from the river enters the lake, particles of which size will usually settle out *first*?

- A) silt C) clay
 B) pebbles D) cobbles

- 16) Transported sediments are usually deposited at locations in which
- A) the freezing and thawing of water occurs
 B) an increase in the physical weathering of rocks occurs
 C) the chemical breakdown of rocks occurs
 D) a decrease in the speed of the agent of erosion occurs
- 17) The diagram below represents a top view of a river emptying into an ocean bay. *A-B* is a reference line along the bottom of the bay. Which characteristic would most likely decrease along the reference line from *A* to *B*?

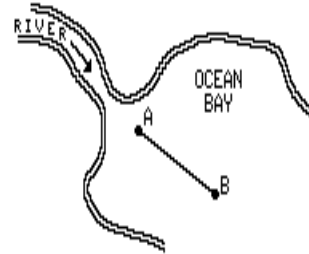

- A) the density of the water
 B) the size of the sediments
 C) the amount of salt in solution
 D) the depth of the water
- 18) Compared to a low-density spherical particle, a high-density spherical particle of the same size will sink through water
- A) more rapidly
 B) more slowly
 C) at the same rate
- 19) The rate at which particles are deposited by a stream is *least* affected by the
- A) size and shape of the particles
 B) velocity of the stream
 C) stream's elevation above sea level
 D) density of the particles

Questions 31 through 33 refer to the following:

A group of students collected rounded, well-sorted mineral particles from a stream that flowed over only coarse-grained igneous bedrock. They sorted the particles by mineral type and then mixed equal volumes of all four minerals together and poured the mixture into a tube of water. The data table below lists the minerals. Figure *A* shows the deposit formed on the bottom of the tube as a result of the deposition of the particles.

MINERAL	AVERAGE PARTICLE DIAMETER
Plagioclase feldspar	0.2 cm
Quartz	0.2 cm
Hornblende (Amphibole)	0.2 cm
Olivine	0.2 cm

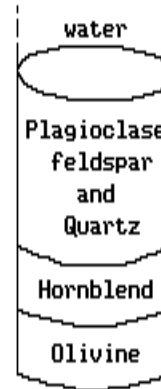

Figure A

- 31) The experiment was repeated using a second plagioclase sample with the original samples of the other minerals. What difference between the first and second samples of plagioclase would best explain the change in the pattern of deposition shown in figure *B*?
- 32) As shown in figure *A*, which mineral appears to have the fastest settling rate?
- A) olivine
B) quartz
C) hornblende
D) plagioclase
- 33) The pattern resulting from the deposition of the mineral particles, as shown in figure *A*, is best explained by the fact that the particles have different
- A) volumes
B) circumferences
C) surface areas
D) densities

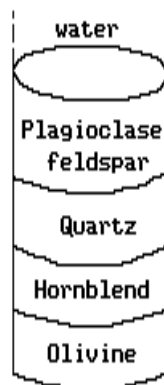
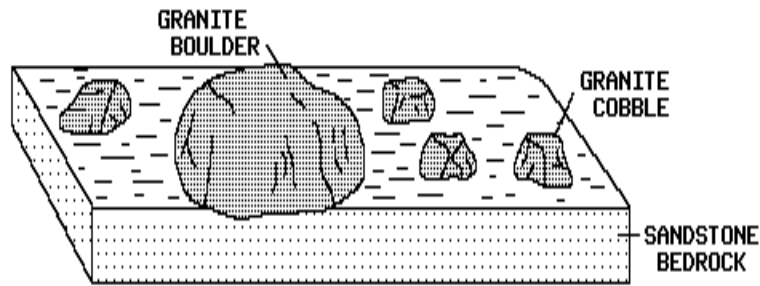

Figure B

- A) Particles from the second sample of plagioclase had greater density.
- B) Particles from the second sample of plagioclase were larger.
- C) Particles from the second sample of plagioclase had greater total volume.
- D) Particles from the second sample of plagioclase had flatter shapes.

Questions 34 and 35 refer to the following:

The diagram below represents a surface and cross-sectional view of a portion of the Earth 15 kilometers from a mountain range.



- 34) According to the *Earth Science Reference Tables*, what must be the size of the boulder?
- A) greater than 25.6 cm in diameter
 - B) 0.2 to 6.4 cm in diameter
 - C) less than 0.2 cm in diameter
 - D) 6.4 to 25.6 cm in diameter

- 35) The best explanation for the presence of an isolated boulder in this location is that the boulder was
- A) transported there by a glacier
 - B) eroded from a limestone cliff
 - C) placed there by a volcanic eruption
 - D) deposited there by a slow-moving stream

Questions 36 and 37 refer to the following:

The maps below show the stages in the growth of a stream delta. Point X represents a location in the stream channel. The cross section of a stream shows rock particles transported in the stream at a point close to its source.

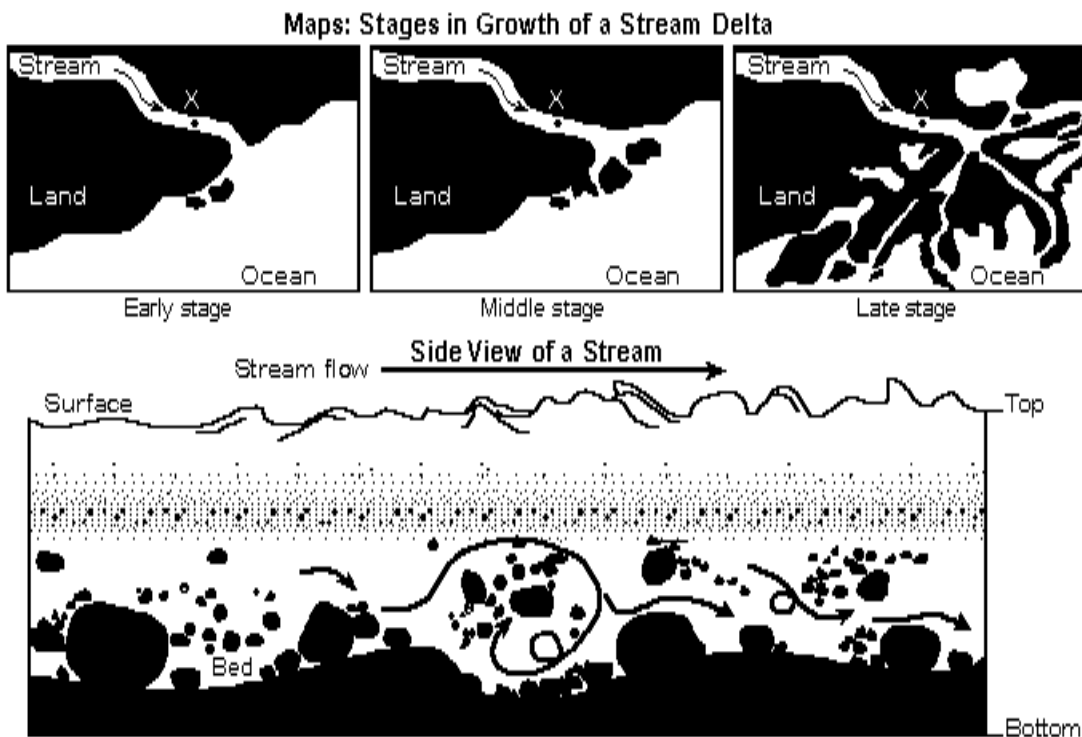

- 36) Which characteristics are most likely shown by the sediments in the delta?
- A) large cobbles deposited in parallel lines
 - B) round grains deposited in layers
 - C) jagged fragments deposited in elongated hills
 - D) unsorted mixed sizes deposited in scattered piles

- 37) A decrease in the velocity of the stream at location *X* will usually cause an increase in
- A) the size of the particles carried by the stream
 - B) the amount of material carried by the stream
 - C) deposition within the stream channel
 - D) downcutting by the stream

Questions 38 and 39 refer to the following:

The map below shows a stream flowing into a lake. Letters *A* through *F* represent locations in the stream and lake.

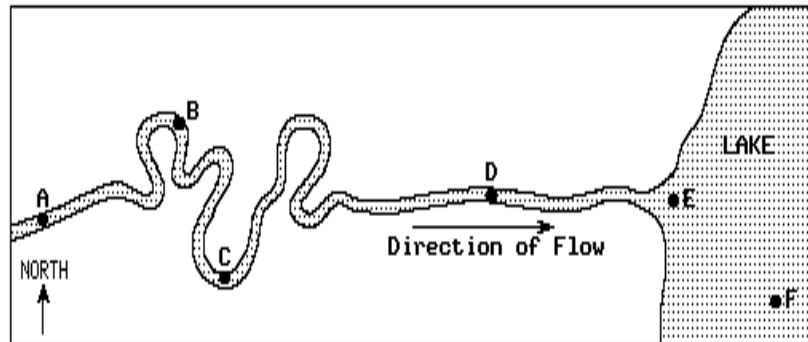

- 38) Where would the *greatest* amount of sediments most likely be deposited in this system?
- A) *B*
 - B) *F*
 - C) *D*
 - D) *E*

- 39) Which kind of sediment would probably be deposited farthest out in the lake? [Refer to the *Earth Science Reference Tables*.]
- A) silt
 - B) sand
 - C) clay
 - D) pebbles

- 40) A large glass cylinder containing a mixture of sediments of the same density and water is shaken. Which drawing below best represents the result after settling?

KEY:

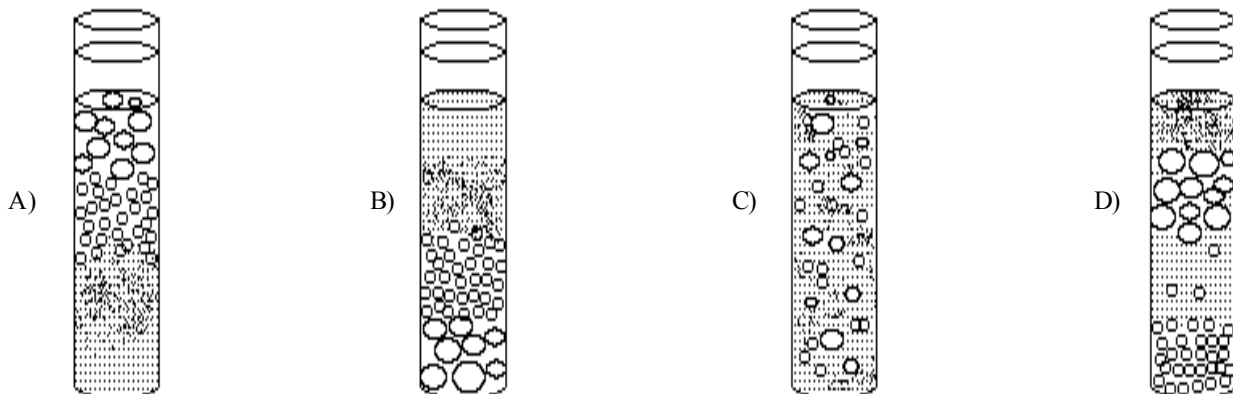

- 41) Diagram I below shows the paths of two streams over the Earth's surface. Diagram II shows the longitudinal profile of the major stream.

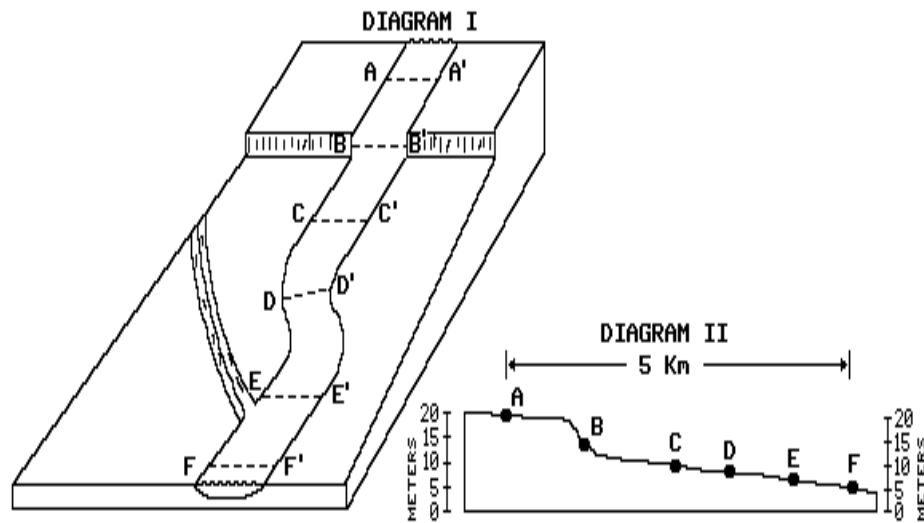

At which location would the water in the stream have the *greatest* potential energy?

- A) B B) A C) E D) C
- 42) The map below shows the top view of a meandering stream as it enters a lake.

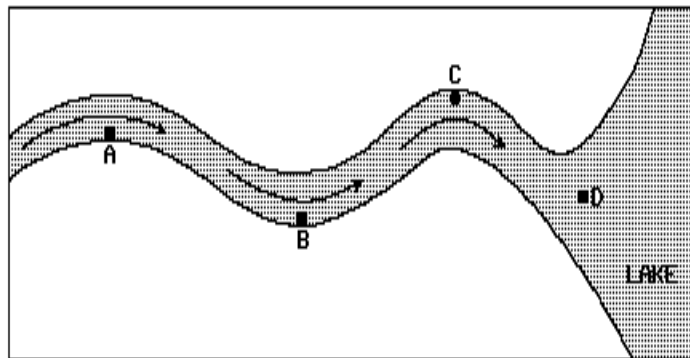

At which points along the stream are erosion and deposition dominant?

- A) Erosion is dominant at B and C, and deposition is dominant at A and D.
 B) Erosion is dominant at A and D, and deposition is dominant at B and C.
 C) Erosion is dominant at A and C, and deposition is dominant at B and D.
 D) Erosion is dominant at B and D, and deposition is dominant at A and C.

Questions 43 through 46 refer to the following:

The cross-sectional diagram below shows the pattern of deposition of stream-carried sediments on the ocean floor.



Questions 49 through 52 refer to the following:

The cross-sectional diagram below shows a sediment-laden stream entering the ocean. The ocean is divided into four zones *A*, *B*, *C*, and *D*.

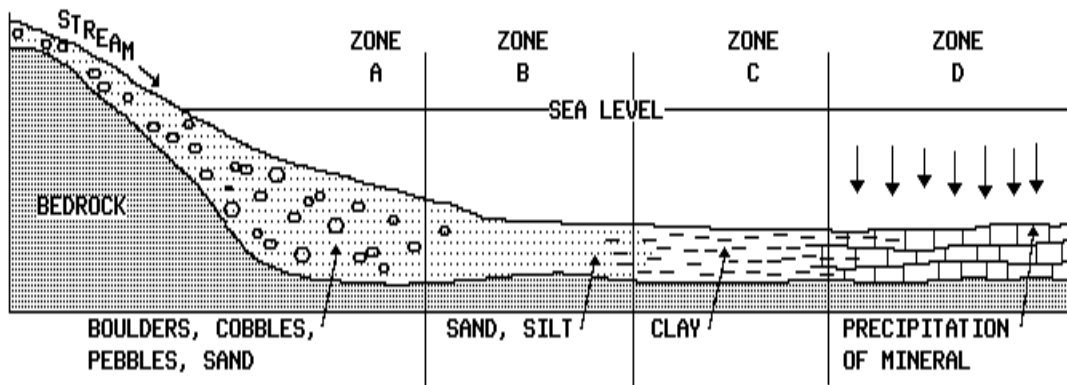

- 49) In which zone would the stream normally deposit particles of *largest* size?
 A) *B* B) *D* C) *C* D) *A*
- 50) Which change in the stream system would most likely cause the deposition of larger particles to be farther offshore?
 A) a decrease in the stream's gradient
 B) an increase in the density of large particles
 C) an increase in the stream's velocity
 D) a decrease in the quantity of large particles
- 51) Which zone would contain particles mostly in the range of 0.05 to 0.10 centimeter in diameter? [Refer to the *Earth Science Reference Tables*.]
 A) *C* B) *D* C) *B* D) *A*
- 52) Which material would most likely be held in suspension in zone *D*?
 A) sand C) cobbles
 B) silt D) colloids